

# Private Equity: Driving the transition to a green economy



SWEEP

How to measure and address  
your financed emissions

Guide

Private Equity

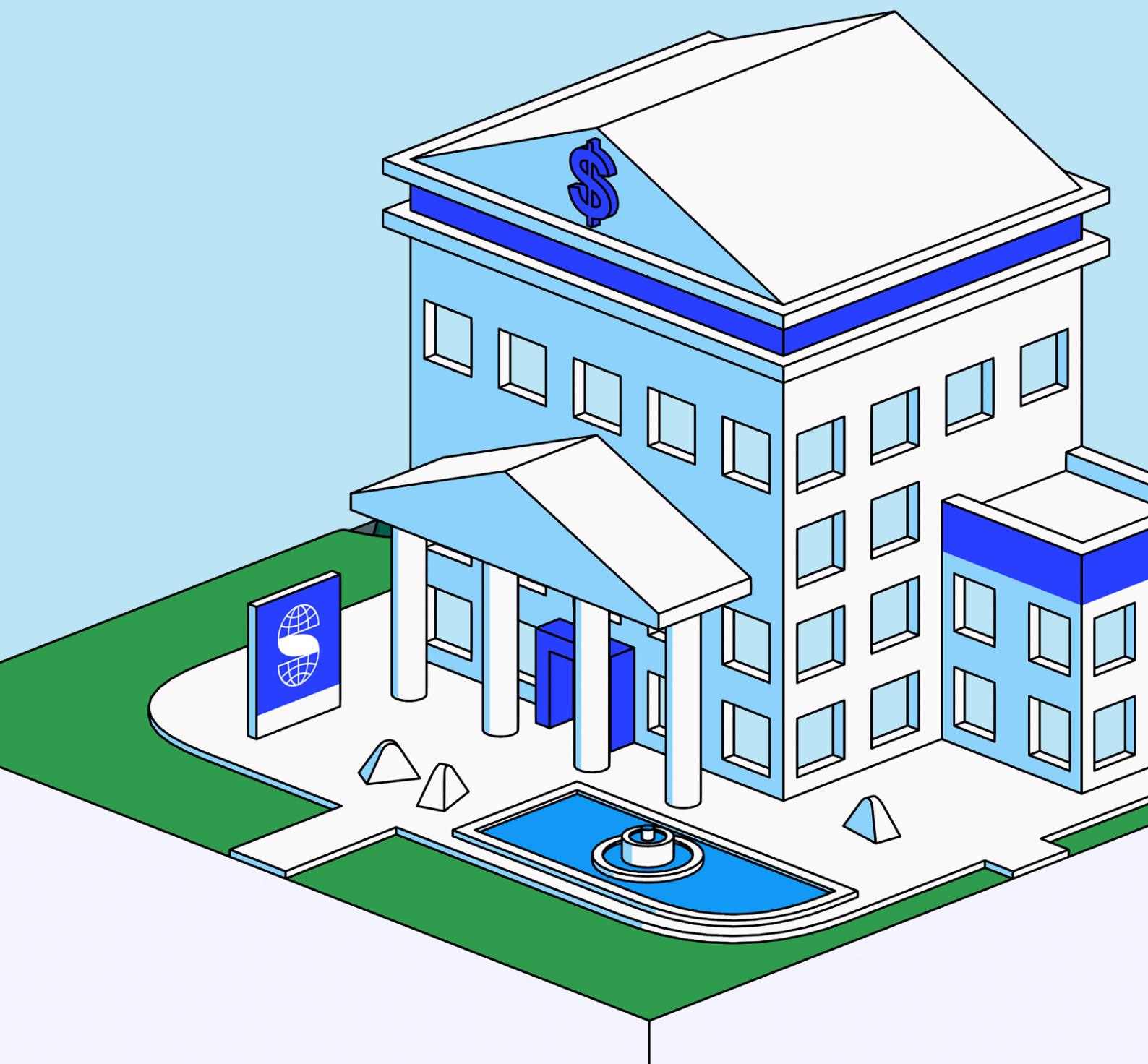

# Contents

<b>Introduction</b>	<b>3</b>
<b>I. How to set your business objectives</b>	<b>3</b>
<b>II. How to define your carbon management requirements</b>	<b>5</b>
<b>III. How to decide who to involve</b>	<b>6</b>
<b>IV. Key questions to ask</b>	<b>7</b>

## Lead author



**Marie-Anne Vincent**  
VP of Climate Finance at Sweep

## Editors



**Ewa Jozefkowicz**  
Content Manager at Sweep



**Cecile Bussy**  
Content and Communications at Sweep

## Reviewers



**Elodie Broad**  
Head of Impact and ESG at Balderton Capital



**Marie Eckland**  
Founder, 2050

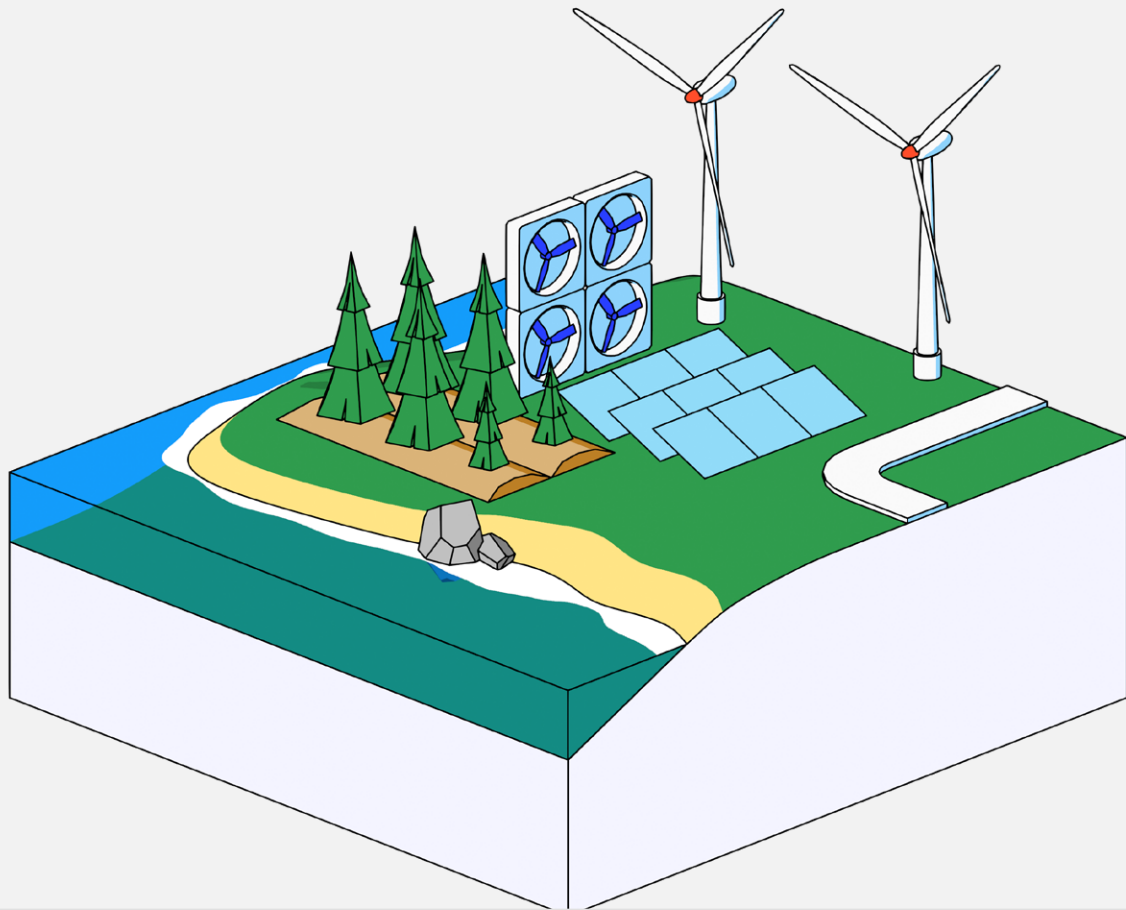

## Introduction

### Environmental, social, governance (ESG)

ESG is a framework used to assess an organization's business practices and performance on various sustainability and ethical issues. It also provides a way to measure business risks and opportunities in those areas.

Private equity (PE) is evolving. Over the past decade, deal activity and size have both increased significantly, largely due to the low-interest rate environment and increased valuation multiples. We've also seen a considerable rise in new private equity firms, particularly those focussed on niche industries and geographies.

This growth across the sector has led to increased regulator and investor scrutiny, coupled with a demand for greater transparency and accountability.

We've also seen an increased focus on environmental, social, and governance (ESG) issues, with many private equity firms integrating ESG considerations into their investment decision-making processes. In fact, according to Atomico's recent State of European Tech Report, 35% LPs chose not to commit to a GP relationship primarily due to ESG concerns.

Europe's push on purpose-driven investment has increased over the past 18 months (while it has decreased in the US and Asia), and it now represents \$54B cumulated investments since 2018 – highlighting that it's a key growth factor in this part of the world.

This is great progress, but it's just the beginning of the journey. As a private equity firm, you have a crucial role to play in driving the transition to a green economy. Crucially, you shouldn't act in a vacuum and you can't simply focus on your own carbon footprint.

## With great power comes great responsibility

At Sweep, we believe that private equity has a key role to play in global decarbonization for three reasons:

### 1. Capacity to invest

In 2021, the PE industry had \$6.3T in assets under management. Those assets are projected to exceed \$11T by 2026. We believe that the amount of investment needed to finance the climate transition can be funded from this sum.

Private equity-owned companies operate on a longer time horizon compared to the listed markets. The average holding period for portfolio companies has increased from about two years in the industry's early days to about five years today. This means that it's high time to acknowledge that climate risk is a financial risk.

It's also important to note that most of the pre-acquisition due diligence processes now include an assessment of the company's resilience to climate change, both in terms of physical and transition risks.

### 2. Capacity to innovate

To achieve net zero emissions by 2050, the world needs to shift towards a low carbon economy. We need to be creative by inventing and financing new solutions, new technologies and new business models, and the private market is better placed than listed markets to support this innovation. We also need to come up with new models to assess portfolio risk, valuation and performance – to truly embrace environmental and social performance on top of financial performance.

### 3. Capacity to influence

Compared to listed assets, private equity is known for its control model of ownership. Through the considerable influence they can leverage over portfolio companies, private equity firms can play a crucial engagement role in getting companies to accurately account for and manage their emissions, adopt decarbonization strategies, and more generally increase their focus on climate action – this can help differentiate companies' operating models and build enterprise value.

But importantly, influence should be structurally placed at the board level. Investors should put climate performance KPIs as part of the board's scope. In section 3 of this guide, we'll discuss targets. It's important that these are set at each portfolio company's board and not just at the investors' level. It's only then that they'll have a fair chance of being met.

#### Physical risks

These refer to the actual and potential impacts of climate change and other environmental factors on physical assets, infrastructure, and supply chains. These risks can have direct financial impacts on businesses and investors, such as damage to property, increased insurance premiums, and reduced revenue.

#### Transition risks

These refer to the potential economic and financial impacts of the transition to a low-carbon economy, as countries and companies seek to reduce their greenhouse gas emissions and shift to cleaner energy sources. This transition may lead to changes in policy, technology, markets, and consumer preferences.

# Why it's important to address your financed emissions

According to The Carbon Disclosure Project's (CDP)'s [Time to Green Finance](#) report, financed emissions are 700 times greater than the average financial organization's own emissions. This is why collaboration is key to driving an effective climate strategy. [As investors, private equity firms have the power to influence the behaviors of companies, and by extension, entire industries.](#)

## Scope 3

Scope 3 emissions are a category of greenhouse gas (GHG) emissions originating from business operations by sources that are not directly owned or controlled by an organization.

## What are financed emissions?

Financed emissions are the emissions that originate from your company's assets and investments. They are considered indirect emissions and fall under Scope 3 (See the explanation of scopes on page 8).

As a private equity firm, you're likely facing increasing pressure to measure and report your financed emissions due to several factors. Firstly, there's a growing demand from investors, particularly institutional investors, for more transparency and disclosure on environmental, social, and governance (ESG) factors, including climate change.

Secondly, there is a growing regulatory pressure on financial institutions to disclose their climate-related risks and opportunities. Several countries have introduced regulations that require financial institutions to disclose their climate-related risks and to report on their progress towards meeting climate targets (see our regulation section below).

You're also likely to discover that measuring and managing your financed emissions can help you identify opportunities to improve the sustainability and resilience of your portfolio companies.

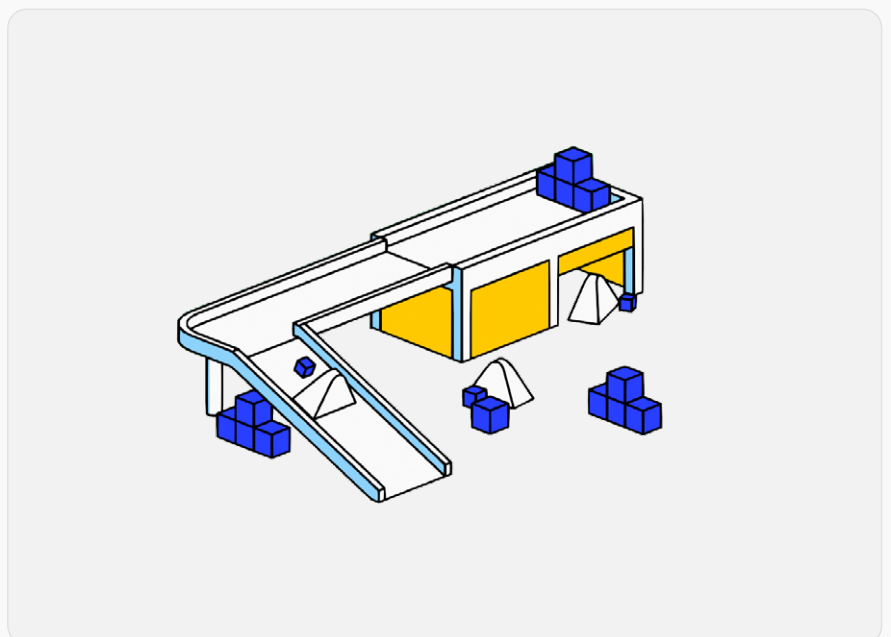

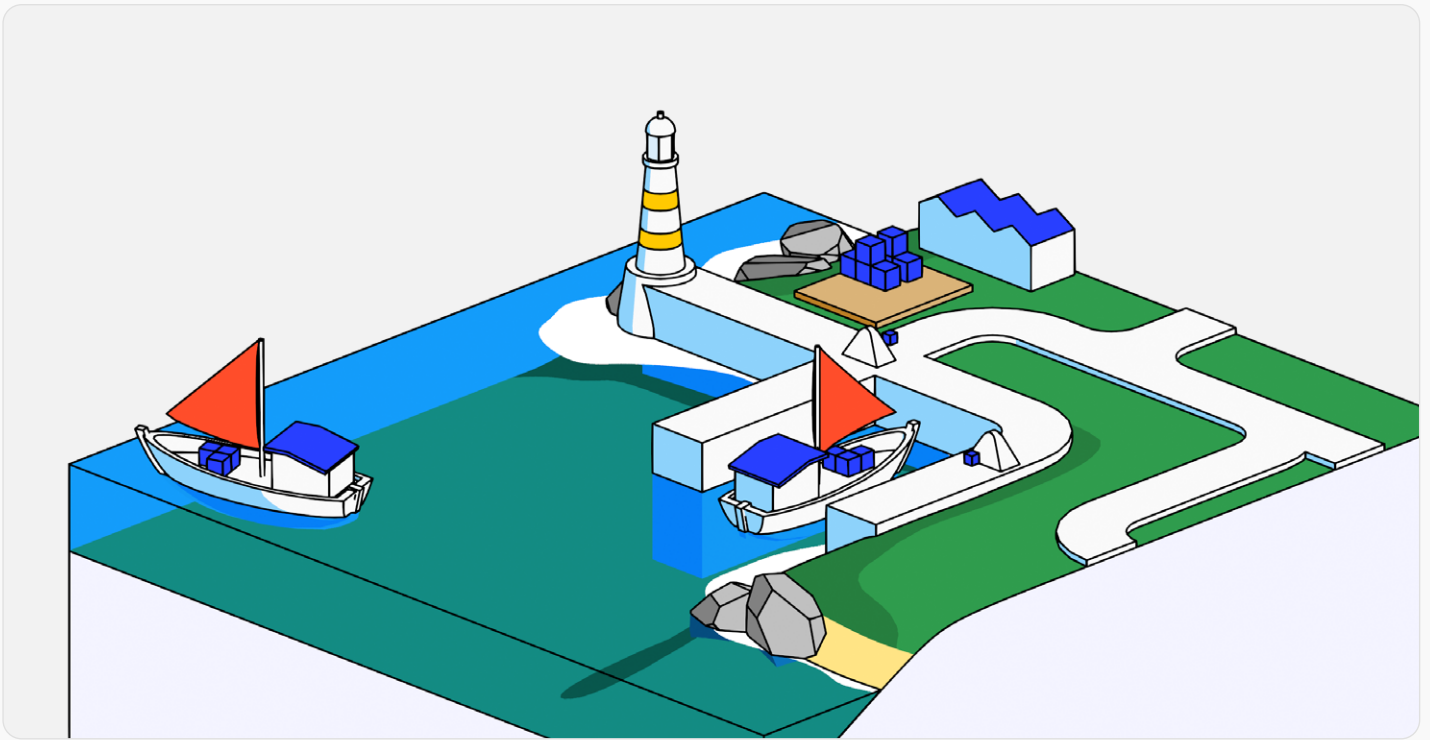

#### Your Climate Suite

Firms are recognizing the need to take action on climate change and are looking to build an impactful team of leaders who can drive progress. Learn how to build your **Climate Suite**, from identifying key team members, to establishing clear goals and metrics, and creating a culture of collaboration and accountability.

#### The chain of influence:

**LPs → GPs → Portfolio Companies**

There is an increasing push for private equity firms to disclose sustainability information, both from investors and from society as a whole.

**Limited partners (LPs)**, who provide the capital for private equity funds, are becoming more vocal about their expectations for ESG considerations.

This influences **general partners (GPs)**, who manage the private equity funds, to implement sustainable practices and report on their sustainability performance.

GPs, in turn, influence their **portfolio companies** to improve their sustainability performance, often through targeted initiatives and reporting requirements.

The degree of influence that GPs can exert on portfolio companies can vary depending on factors such as the type of private equity fund and the level of ownership. For example, in buyout funds where the private equity firm is the majority shareholder, they typically have strong influence or control over the portfolio company's sustainability practices. In growth or venture capital funds where the private equity firm has a minority shareholder position with a board seat, they have some influence on the portfolio company's sustainability practices. However, in cases where the private equity firm is a minority shareholder without a board seat, they may have little influence on the portfolio company's sustainability practices.

As more LPs demand transparency and disclosure around ESG issues, private equity firms and their portfolio companies are likely to face increasing scrutiny and pressure to demonstrate their sustainability credentials.

# Frameworks for measurement

## The GHG Protocol

The protocol was developed by the World Resources Institute (WRI) and the World Business Council for Sustainable Development (WBCSD) and has become the global standard for greenhouse gas accounting. It provides a comprehensive framework for measuring and reporting emissions.

The GHG Protocol and Partnership for Carbon Accounting Financials (PCAF) are two widely used frameworks for measuring and managing greenhouse gas emissions in the finance sector.

## Category 15 of the GHG Protocol

The GHG Protocol is a standard designed to help you identify and calculate your firm's carbon footprint across your entire investment portfolio.

It has divided Scope 3 into 15 categories, with category 15 being designated as "Investments" and intended for banks and investment funds. This section states that financed emissions must be incorporated into the company's GHG reduction strategy.

For instance, if your investment fund owns shares in a grocery company and your direct activities have a low carbon footprint, you still need to account for the GHG emissions you finance through your shares in the grocery firm. Owning assets in such a company increases your investment fund's climate impact.

## The Partnership for Carbon Accounting Financials (PCAF)

PCAF is an industry-led initiative to enable private equity firms and other financial institutions to consistently measure and disclose their financed emissions.

In November 2020, the PCAF released the first edition of the Global GHG Accounting and Reporting Standard for the Financial Industry. It draws upon the GHG Protocol to establish a framework for measuring and attributing emissions stemming from particular asset classes.

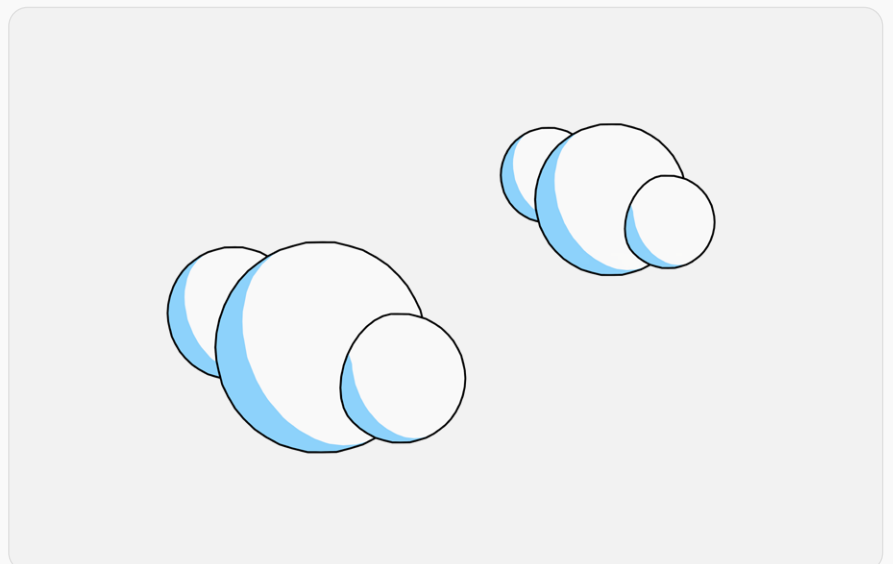

## Part 2

These six asset classes include:

- Listed equity and corporate bonds
- Business loans and unlisted equity
- Project finance
- Commercial real estate
- Mortgages
- Motor vehicle loans

This guidance concentrates on the private equity sector, which correlates with the "business loans and unlisted equity" approach.

As mentioned above, financed emissions which fall within the Scope 3 category 15, represent the most significant emission category for private equity firms. This is why the SBTi Private Equity Sector Guidance necessitates emission targets to be established for category 15, with the choice to establish targets for categories 1 through 14.

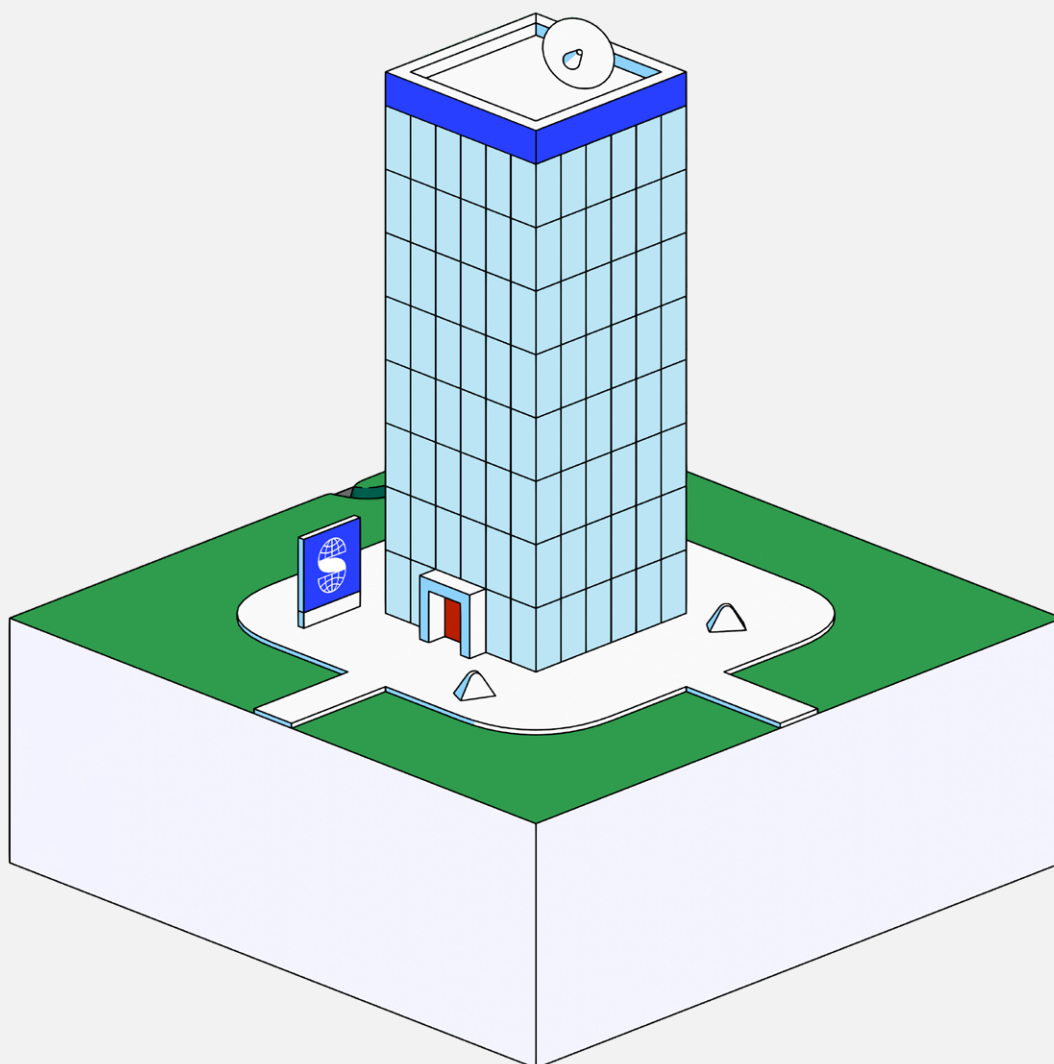



# Your decarbonization journey

Below, we outline each of the key steps in your sustainability journey, with a particular focus on addressing your financed emissions.

## 1. Prepare to measure your financed emissions

Before you embark on your emission measurement journey, you'll need to set your Greenhouse Gas (GHG) inventory boundaries and a baseline for reporting.

### How to set reporting boundaries

#### Organizational boundaries

First, you need to identify emission sources for which you will collect data across all three scopes.

### Scopes – A quick recap

#### Scope 1

Scope 1 emissions are direct emissions from sources that are owned or controlled by your firm, such as emissions from office buildings or company vehicles.

#### Scope 2

Scope 2 emissions are indirect emissions from the generation of purchased electricity, heat, or steam that your firm uses.

#### Scope 3

Scope 3 emissions are all other indirect emissions that aren't included in Scope 2. It includes 15 categories of emissions, such as purchased goods and services, capital goods, employee commuting, business travel, waste generated in operations, and use of sold products.

The three Scopes were established by the [Greenhouse Gas \(GHG\) Protocol](#) to help governments and business leaders to understand, quantify, and manage their emissions.

There are two main approaches to setting organizational boundaries. First, you can find out to what extent your company owns other entities: The equity approach. Second, you can list the entities over which you have financial or operational control. The difference between operational control and financial control is shown below.

## Part 3

### The Sustainability Accounting Standards Board (SASB)

This is an independent nonprofit organization that sets standards for sustainability accounting and reporting. The SASB was founded in 2011 with the goal of providing investors with standardized information on sustainability performance that is comparable across companies and industries.

- **Operational control:** A company has operational control over an operation if it or one of its subsidiaries has the full authority to introduce and implement its operating policies at the operation.
- **Financial control:** The company has financial control over the operation if the former has the ability to direct the financial and operating policies of the latter with a view to gaining economic benefits from its activities.

You can report GHG emissions pro rata if you apply the equity share approach. That is, if you own 30% of the shares then you report 30% of the emissions. When you apply a control approach (financial or operational) you can report 100% of the emissions in most cases.

### Operational boundaries

Operational boundaries refer to the classification of emission sources according to Scope 1, 2, and 3.

The Scope 3 standard defines 15 GHG emission categories which may or may not be relevant for your organization. Setting operational boundaries thus requires an evaluation of which categories are most relevant for your operations. (See Scope 3 Screening below).

You can find the Scope 3 categories which are likely to be important for your sector in [CDP guidance](#) and in the standards developed by the Sustainability Accounting Standards Board ([SASB](#)). Emerging standards are now emphasizing the importance of calculating GHG emissions across your entire value chain – meaning that the reporting of Scope 3 emissions is no longer voluntary. Note however that only relevant Scope 3 categories need to be reported. It isn't necessary to report all 15 categories.

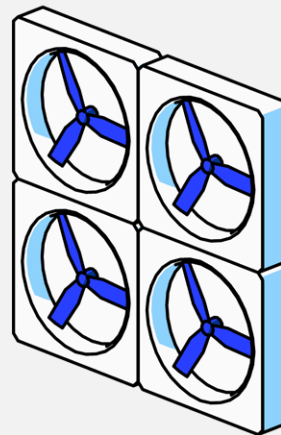

You can set a base year once you have complete and verifiable data for a reporting period. Typically, this base year is recent and representative. “Representative” means that the GHG emissions are typical for normal operations.

### Scope 3 Screening

The GHG Protocol Corporate Value Chain Standard recommends that companies should conduct a screening process to identify activities that generate the most significant emissions, and then prioritizing them based on their **materiality** and **relevance** to the company's operations.

#### GHG Protocol Corporate Value Chain Standard

The Corporate Value Chain Standard is designed to help companies identify opportunities for reducing emissions throughout their value chain, and to engage with suppliers and other stakeholders to collaborate on emissions reduction efforts. It is often used in combination with the Corporate Standard to provide a more comprehensive understanding of a company's carbon footprint and opportunities for emissions reduction.

**Materiality** refers to the significance of a Scope 3 emission category to the company's business operations, financial performance, or stakeholder interests. Materiality is determined by assessing the magnitude of the emissions, the potential risks or opportunities associated with the emissions, and the level of stakeholder interest or concern in these emissions. **Relevance** refers to the connection between a Scope 3 emission category and the company's core business activities or strategy.

A Scope 3 emission category is considered relevant if it's connected to the company's value chain or supply chain, its products or services, or its overall sustainability strategy. A relevant Scope 3 emissions category may also be associated with regulatory or reputational risks, or emerging opportunities for innovation or efficiency gains.

The GHG Protocol Corporate Value Chain Standard recommends completing a screening of all 15 Scope 3 categories to indicate which categories are relevant and material before beginning data collection.

Screening can be conducted using estimates or industry-average data, in order to obtain a top level assessment of emissions for each of the 15 categories.

## 2. Start measuring your portfolio emissions

Set your inventory boundaries and baseline? Great. You now have two options for calculating your financed emissions: Primary or secondary data.

**Primary data** comes from specific activities within your portfolio and provides a more accurate representation of your firm's value chain emissions. However, it can be costly, and the source and quality of the data may not always be verifiable.

**Secondary data** uses industry average data and is often a cheaper and less time-intensive approach. However, it isn't as accurate and is recommended only for less material Scope 3 categories or when primary data is unavailable. It also limits your ability to track GHG emission reductions and progress against targets.

The **accuracy of data** depends on the level of specificity of the data source. You should be pragmatic in your approach to Scope 3 and focus on your most strategic funds in the first instance.

### The Pareto Principle

Assess your portfolio using the Pareto principle of 80-20: 20% of your investments are likely responsible for 80% of your financed emissions.

Focus on these investments first, and get them on board by making more exact data collection as simple as you can. An effective way to do this is providing your internal teams with tools to automate the process.

### How Sweep can help

If you don't have exact portfolio company data at your disposal, you can still obtain a baseline measurement for your portfolio emissions. Our platform is specifically designed to suit companies with varying levels of data maturity.

#### We can help you to

1. Model your portfolio emissions using benchmark data and identify your emission hotspots. We use industry averages as a starting point and use CDP industry benchmarks.
2. Send each portfolio company a straightforward climate survey to calculate Scope 1, 2, 3 emissions based on activity data. By doing that, you are also supporting the companies in your portfolio to embark on their own climate journey. Note that you can adapt our climate surveys to suit your needs.



## Part 3

### 3. Set your targets

An important next step is setting collaborative emission reduction targets. This will provide a clear goal for your portfolio companies to work towards and help to measure their progress.

You can use science-based targets (SBTs) as a guide to set ambitious and achievable targets that are aligned with the Paris Agreement. SBTs are GHG emission reduction targets that are consistent with limiting global warming to 1.5°C above pre-industrial levels.

It's worth setting separate targets for your Scope 1, 2, and 3 emissions, either absolute or intensity-based.

#### Science-based targets (SBTs)

SBTs are GHG emission reduction targets that are consistent with limiting global warming to 1.5°C above pre-industrial levels.

#### Absolute emission targets

Absolute emission targets refer to a specific amount of emissions that your firm commits to reducing or avoiding over a given period of time. This target is set in terms of the total amount of emissions and isn't dependent on the growth of your business, or the profits made in a given year.

Example: Firm A pledges to reduce its financed emissions by 40% by 2030.

#### Intensity-based emission targets

Intensity-based emission targets refer to a reduction in emissions per unit of economic activity. They allow firms to set emission reduction targets while at the same time accounting for growth or business changes (such as mergers or acquisitions).

Example: Firm B pledges to remove 5 metric tons of CO<sub>2</sub> per \$1M invested.

#### How Sweep can help

Sweep enables you to take the lead on your decarbonization strategy, and support the transition to a low carbon economy.

Using our platform you can easily set targets at different levels: for portfolio companies, funds, or entities, and cascade the fund temperature alignment back to them.

The network approach is key to collaborative reduction.

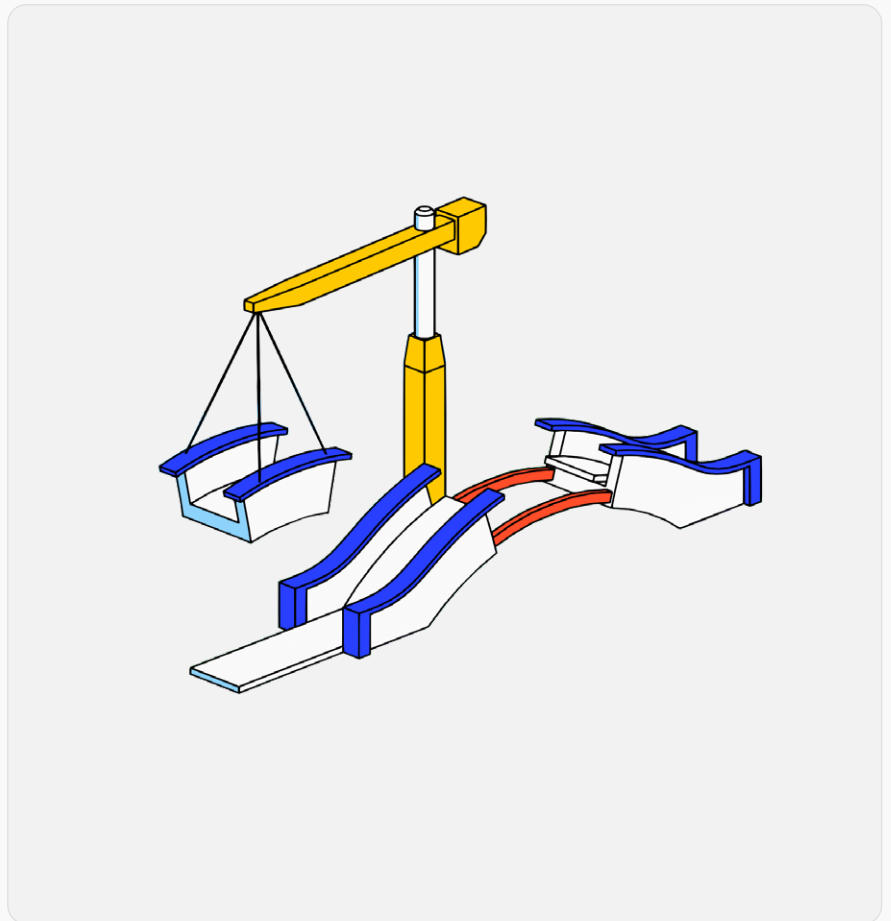

### Climate-related risks

These risks refer to the potential negative impacts of climate change on an organization. It includes the potential for adverse effects on livelihoods, economic, social and cultural assets.

## 4. Plan your reduction activities

Once you've set your targets, it's time to start implementing reduction activities. We would advise starting with two or three key initiatives and engage your portfolio companies in these. Then check in regularly to track your joint progress against targets.

### A targeted approach to reduction

A data-driven strategy for carbon reduction allows for more precise targeting, increased efficiency, and accountability in building a more sustainable business.

Sweep can help. We can empower you to get a thorough understanding of carbon emissions across your portfolio, enabling a more targeted approach to reduction.

### Linking reduction to value creation

While you're identifying the main sources of your emissions, you should simultaneously think about the most effective methods of reducing them. This involves documenting the cost of investment and the potential benefits that can be gained from these actions, such as cost savings from energy efficiency, an increase in market share, or a reduction in regulatory and climate-related risks. It's important to explicitly connect decarbonization measures to value creation in order to obtain both internal and external support for these initiatives.

## Part 3

### Ways to get started with reduction

There are various ways in which you can engage with your portfolio companies to implement reduction initiatives. Below are just a few:

#### Sweep School

Sweep School is a self-paced training program to help platform users take the lead on their company's climate journey using Sweep. Mixing video, visual, and written content, it includes step-by-step guides, industry use cases, and educational materials on carbon management.

#### Financial support

You might also consider providing your portfolio companies with financial support to help them achieve emissions reduction goals. For example, you might choose to finance renewable energy projects, such as solar or wind farms, or provide loans for energy efficiency upgrades.

#### Technical support

You could also think about offering technical expertise to help portfolio companies identify and implement emission reduction measures, such as conducting energy audits or developing sustainability plans.

#### The importance of consistent collaboration and feedback

Every portfolio company has a unique journey towards decarbonization, but there is potential for all companies to benefit from the experiences of others in the portfolio. It's definitely worth creating channels for sharing knowledge and learning from the decarbonization strategies of others.

You could also bring together operational leaders focused on decarbonization for regular training and networking. That way, your portfolio companies will be better placed to establish best practices that become standard operating procedure across the portfolio. Sharing tools, processes, and expert support creates scale efficiencies that can benefit them all. Additionally, shared learning can help companies overcome the complex technical and regulatory challenges that often hinder decarbonization efforts.

#### How Sweep can help

Using Sweep, you can easily see a snapshot of your entire portfolio's footprint. You can then identify emission 'hotspots' thanks to automatic industry benchmarks.

### 5. Report your progress

When it comes to reporting, one of your key KPIs will be your portfolio companies' progress on their Scope 3 emissions. This will require you to share your reporting tool with each of them and to regularly monitor progress against targets. Each individual company target will fit into your own overall climate target.

## Part 3

### Climate classification

Some companies choose to classify their Investments based on their progress towards decarbonization. For example, you might choose to use a scale like this:

**Level 1:** Investments that have achieved net zero for Scopes 1 and 2, and their Scope 3 reduction trajectories are aligned with a 2°C max increase in temperature.

**Level 2:** Investments whose Scope 1 and 2 trajectories are aligned with a 2°C max increase in temperature and their Scope 3 calculations are 80% based on physical data.

**Level 3:** Investments whose Scope 1 and 2 trajectories are aligned with a 2°C max increase in temperature and their Scope 3 calculations are 60% based on physical data.

**Level 4:** Investments that have calculated their Scope 1 and 2 emissions based on physical data and their Scope 3 carbon footprint based on spend-based data.

**Level 5:** Investments that are using a spend-based approach across all scopes to calculate and act on their carbon footprint.

Such classifications enable you to more easily demonstrate progress against targets.

E.g. In January 2020, we had 10% of investments at level 3, 20% at level 4 and 70% at level 5. But in January 2023, we have 5% of investments at level 1, 15% at level 2, 30% at level 3 and the remainder at level 4.

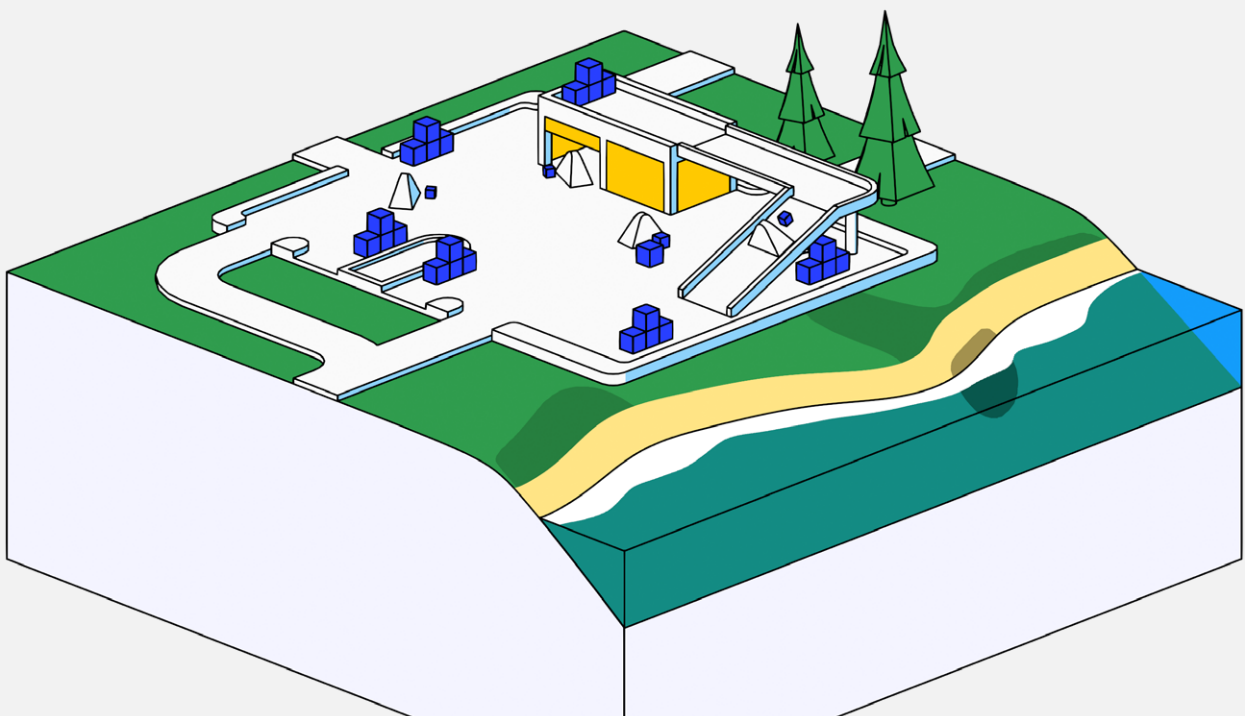



### What's the temperature of your portfolio?

To help private equity firms align their investments with the Paris Agreement, the SBTi developed the concept of a finance portfolio temperature. This is a metric that calculates the average temperature increase that would result from the greenhouse gas emissions associated with a PE's investment portfolio. The finance portfolio temperature allows investors to evaluate the climate impact of their investments and to set targets to reduce the temperature increase associated with their portfolios over time.

#### The SDR vs the SFDR

The UK Sustainable Disclosure Regulation (SDR) and EU Sustainable Finance Disclosure Regulation (SFDR) are both sustainability disclosure regulations for financial market participants. Although the SDR is generally considered to be the UK's answer to the EU's SFDR, the two regimes are far from being aligned. Take a look at our [blog post](#) on the key differences.

### Financial sustainability regulations

Your company's financed emissions reports are likely to be requested by a number of stakeholders, including customers, investors, and analysts. Reporting is also essential for complying with regulations. These depend on your region and scope of operations.

The number of countries with mandatory disclosures relating to financed emissions is on the rise. Here are the key ones that you should be aware of:

#### Europe

The Sustainable Financial Disclosure Regulation (SFDR), led by the European Commission, sets out sustainability-related disclosure requirements for financial market participants, including asset managers, investment funds, insurance companies, and pension funds, that provide financial products or services within the EU. The regulation requires these entities to disclose information about the environmental, social, and governance (ESG) risks and impacts of their products, including how they integrate sustainability into their investment decisions and how they communicate about sustainability to their clients.

The SFDR aims to create a more sustainable financial system by providing investors with more information about the sustainability of their investments and promoting more sustainable investment practices by financial market participants.

The Corporate Sustainability Reporting Directive (CSRD) was adopted by the European Commission in late 2022. The directive will require companies operating in the European Union (EU) to disclose non-financial information related to sustainability topics. The application of the rules will be phased in gradually between 2024 and 2028, depending on the size and type of the company.

Large public-interest companies with over 500 employees, who are already subject to the existing non-financial reporting directive, will need to comply with the new requirements from 1 January 2024, with their reports due in 2025.

## Part 3

Large companies that are not presently subject to the non-financial reporting directive, but have more than 250 employees and/or €40 million in turnover and/or €20 million in total assets, will need to comply with the CSRD from 1 January 2025, with their reports due in 2026. Listed small and medium-sized enterprises (SMEs) and other undertakings will need to comply from 1 January 2026, with their reports due in 2027. SMEs will have the option to opt-out until 2028. Note that financial organizations that are subject to other EU regulations, such as the Sustainable Finance Disclosure Regulation (SFDR), may be exempt from certain CSRD requirements, provided that they comply with their existing disclosure obligations under these regulations.

### UK

The UK became the first G20 country to make it mandatory for the country's largest businesses to disclose their climate-related risks and opportunities, in line with [Taskforce on Climate-related Financial Disclosures \(TCFD\) recommendations](#).

The [UK Sustainable Disclosure Regulation \(SDR\)](#), led by the UK Financial Conduct Authority (FCA), aims to provide investors with more comprehensive, consistent and comparable sustainability information from issuers and investment managers. It requires these organizations to disclose information related to the ESG risks and impacts of their investments and activities.

### US

In the US, the [Securities and Exchange Commission \(SEC\)](#) requires publicly-traded companies, including financial organizations, to disclose material climate-related risks and impacts in their financial filings. This includes the potential physical risks associated with climate change, as well as the transition risks related to changing market conditions, new regulations, and technological innovations. Note that financed emissions should be included in the disclosure.

#### How Sweep can help

Sweep enables you to respond to Limited Partners (LP) and stakeholder requests with **easy-to-use climate and ESG reporting tools**.

Analyze your financed emissions with market-standard metrics and flexible reports that scale with you (including the TCFD, SFDR, SASB, GRI, and more).

## A collaborative approach is key

If we could leave you with one leading thought, it's that effectively engaging your entire portfolio in your decarbonization strategy is key to achieving your climate targets. It may seem like a daunting task, but with the right education, efficient data collection and collaborative reduction activity, you'll soon be on the right path.

### Ready to get started on a smoother road to decarbonization?

We're here to support you at every step. And your portfolio companies can get started for free!

Our free plan lets them measure their emissions in Sweep – so you can invite all your investments. And once their measurements are in our platform, we can help your portfolio companies get further along their own carbon track.

[Book a demo](#) >

### Trusted by

EURAZEO

mirova

DTCP

Balderton.

andera  
PARTNERS

COATUE

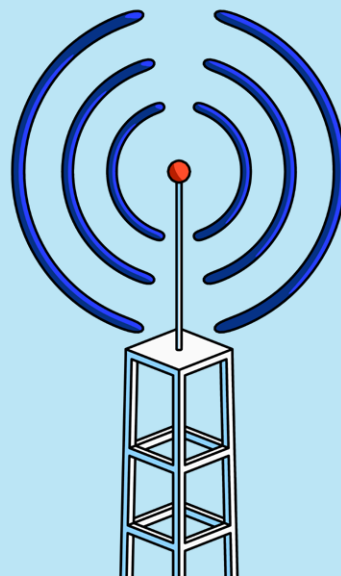

Get in touch

sweep.net  
@sweeptheplanet



**SWEEP**